

Thank you for purchasing the IC-A210/A210E VHF AIR BAND TRANSCEIVER with Icom's state of the art technology. Please read this, not these installation guide and transceiver's instruction manual carefully before installing and operating, not installation and operation.

### IC-A210/A210E SUPPLIED ACCESSORIES

The following accessories are supplied with the IC-A210/A210E. Inspect the quantity of each part carefully.

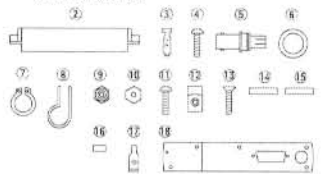
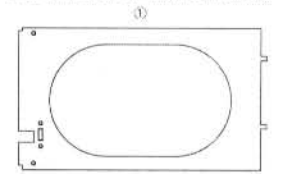

- ① Mounting bracket ..... 1
- ② Molex connector (4359-15) ..... 1
- ③ Molex terminals (4366-GL) ..... 50
- ④ Screws Blind UNC (No. 4 × 12.7) ..... 2
- ⑤ BNC-LP ..... 1
- ⑥ Washer (Icom washer V) ..... 1
- ⑦ C-shaped ring ..... 1
- ⑧ Antenna cable clip ..... 1
- ⑨ Self crimping nut (No. 6) ..... 1
- ⑩ Nut (No. 6) ..... 1
- ⑪ Screws (No. 8 × 12.7) ..... 1
- ⑫ Crimp nuts (No. 6) ..... 1
- ⑬ Screws (No. 6 × 12.7) ..... 6
- ⑭ COM1 sticker ..... 1
- ⑮ COM2 sticker ..... 1
- ⑯ Molex polarizing key ..... 1
- ⑰ Speed nut UNC (No. 6) ..... 4
- ⑱ MB-113 ..... 1

### IMPORTANT

**READ THIS, NOT THESE INSTALLATION GUIDE CAREFULLY** before attempting to install the IC-A210/A210E in an aircraft. This sheet contains important safety instructions for the IC-A210/A210E.

**NEVER** install the transceiver where normal navigation of the aircraft may be hindered.

**NEVER** install an antenna near any aircraft projection, engine, or propeller.

**INSTALL** a circuit breaker between the aircraft battery and the IC-A210/A210E.

Check operation after installation.

Install the IC-A210/A210E according to the following procedure.

### INSTALLATION PROCEDURES

- ① Check the quantity of parts. Refer to **IC-A210/A210E SUPPLIED ACCESSORIES**.
- ② Prepare miscellaneous items required for installation. Refer to **MISCELLANEOUS ITEMS** in **PRECAUTIONS**.
- ③ Prepare required wiring. Refer to **CABLE CONNECTIONS**, **CONNECTOR INFORMATION** and **MOLEX CONNECTOR ASSEMBLY**.
- ④ Assemble supplied mounting bracket and other parts. Refer to **MOUNTING BRACKET ASSEMBLY**.
- ⑤ Cut the mounting hole. Refer to **MARKING MOUNTING HOLES**.
- ⑥ Mount the IC-A210/A210E into the mounting bracket. Refer to **MOUNTING TO THE BRACKET**.
- ⑦ Check the IC-A210/A210E operation. Refer to **OPERATION CHECK**.

### PRECAUTIONS

**Miscellaneous items**  
The following items are required for installation but are **NOT** supplied with the IC-A210/A210E.

- ① VHF air band antenna for the communication band.
- ② Cables.
- ③ Antenna cable with BNC connector (50 Ω).
- ④ Switches are mounted on the aircraft yoke.
- ⑤ Headphones (500 Ω).
- ⑥ Low-impedance carbon or dynamic microphones.
- ⑦ Pre-amplifier for a dynamic microphone.

**Transceiver location**  
Select a location which can support the weight of the transceiver.

**NEVER** place the transceiver where normal navigation of the aircraft may be hindered or where it could cause bodily injury.

**NEVER** bend the cables sharply or place the cables too near the aircraft control cables.

**DO NOT** place the transceiver where hot or cold air blows directly on it.

**AVOID** placing the transceiver in areas with temperatures below -20°C or above +55°C (-4°F to +131°F).

**Battery connection**  
**NEVER** connect the transceiver to a power source using reverse polarity. Reverse polarity will damage the transceiver.

To prevent voltage drops, solder or crimp the cable lug when connecting the DC power cable to the power supply.

**Antenna**  
**NEVER** install an antenna near any aircraft projection, engine or propeller.

Use a 50 Ω, vertically-polarized, VHF air band antenna. VSWR should be less than 2.5:1.  
Mount the antenna on an flat metal surface or install a ground plane of at least 120 cm<sup>2</sup> (18 in<sup>2</sup>).

**Intercom**  
The intercom function is enabled by wiring and installing a yoke-mounted communications/intercom switch.

This function facilitates swift contact between the pilot and co-pilot. 2-pairs of headphones and microphones are required for pilot and co-pilot.

**Interlock**  
When 2 transceivers are installed in your aircraft, wiring for a transmit/receive interlock is required.

To protect the receiver circuit from extremely strong incoming signals, this function prevents receiving while another transceiver is transmitting.

**COMM1 and COMM2 stickers**  
When 2 transceivers are installed, to distinguish them from one another, attach the supplied COMM1 and COMM2 stickers.

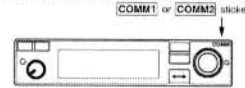

### USING THE MB-113

When installing the IC-A210/A210E into your aircraft, etc., with another connection system using D-sub 15-pin connector, use the supplied MB-113 as described below.

③ Connect the I/O cable connectors and coaxial onto the MB-113 as illustrated below.

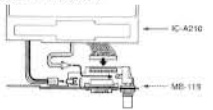

### Attachment

- ① Unscrew the 10 bottom screws, then remove the bottom cover from the transceiver.
- ② Unscrew the 5 rear plate screws.
- ③ Disconnect the I/O cable connectors and coaxial, J3, J4 and J6, then remove the rear plate from the transceiver.

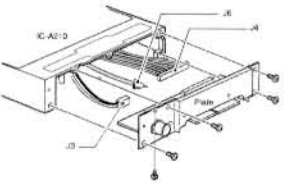

⑤ Attach the MB-113 to the transceiver with the 5 rear plate screws.

⑥ Replace the removed bottom cover and 10 screws.

Icom, Icom Inc. and the Icom logo are registered trademarks of Icom Incorporated (Japan) in the United States, the United Kingdom, Germany, France, Spain, Russia and other countries. Molex is a trademark of Molex Incorporated.

### CABLE CONNECTIONS

**Power cable wiring**  
Use 2 pairs of #18 AWG wires for power and power-grounding connections.

**For Molex (Front view)**

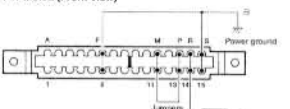

**For D-sub 15-pin (Front view)**

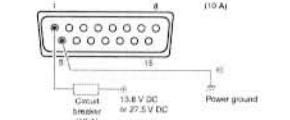

**Circuit breaker**  
To prevent physical damage, a 10 A circuit breaker **MUST** be installed in the DC power line in the aircraft. Install the circuit breaker in the aircraft breaker panel or instrument panel to ensure easy access during flight.

**Ground**  
Connect the transceiver power ground to the airframe ground.

**Jumpers**  
Pins 1, M, P and 13 **MUST** be jumped together with AWG #20 wires or trucket.

**Yoke-mounted channel and frequency exchange switches**

**NOTE:** Channel and frequency selections are available with the Molex connection only.

For the yoke-mounted channel switch and frequency exchange switch, use a 2-position spring loaded rocker switch or 2 separate momentary push switches.

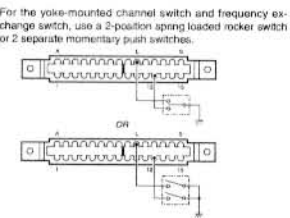

### Transmit/receive interlock connections

When 2 transceivers are installed and both communication antennas are top-mounted, pin N **MUST** be connected to pin 9 of each another transceiver.

### Audio line connections

Use #24 AWG wires for connections.

**For Molex (Front view)**

\*Two places with intercom

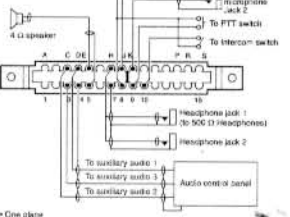

\*One place

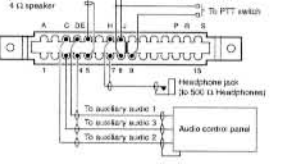

**For D-sub 15-pin (Front view)**

\*Two places with intercom

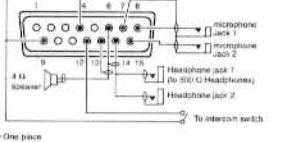

\*One place

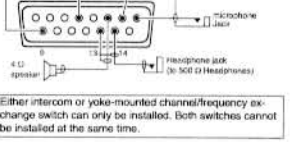

Either intercom or yoke-mounted channel/frequency exchange switch can only be installed. Both switches cannot be installed at the same time.

### CONNECTOR INFORMATION

#### Molex connector

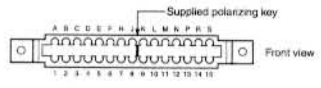

Pin I/O	Description	Pin I/O	Description	Pin I/O	Description
A	- No connection	M	In +13.8 V power ⊕	6	In Aircraft power ⊕
B	- No connection	N	Transmit/receive interlock	7	Out Headphones audio ⊕
C	In Auxiliary audio 2 ⊕	P	- No connection	8	In Mic./Intercom mic. and PTT ⊕
D	In Auxiliary audio 1 ⊕	R	In Aircraft power ⊕ (13.827.5 V)	9	In PTT ⊕*
E	Out External speaker ⊕ (4 Ω/5 W)	S	In Aircraft power ⊕	10	In Intercom switch*
F	In Aircraft power ⊕	T	- No connection	11	In +13.8 V power ⊕
H	Out Headphones audio ⊕ (300 Ω/60 mW)	2	- No connection	12	In Frequency exchange switch*
J	In Microphone 1 ⊕ (600 Ω)	3	In Auxiliary audio 3 ⊕	13	- No connection
K	In Microphone 2 ⊕ (600 Ω)	4	In Auxiliary audio 1, 2, 3 ⊕	14	In Aircraft power ⊕ (13.827.5 V)
L	In Memory channel switch*	5	In External speaker ⊕	15	In Aircraft power ⊕

\*Ground to activate

#### D-sub 15-pin

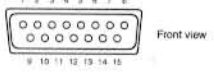

Pin I/O	Description	Pin I/O	Description	Pin I/O	Description
1	In Aircraft power ⊕ (13.827.5 V)	6	Out External speaker ⊕ (4 Ω/5 W)	11	I/O RS-232 Serial data ⊕
2	- No connection (reserved)	7	In Microphone	12	In Intercom select switch*
3	Out RS-232 Serial data ⊕ (TXD)	8	In Microphone 1 ⊕ (600 Ω)	13	Out External speaker and headphones ⊕
4	In PTT ⊕*	9	In Aircraft power ⊕	14	Out Headphones audio ⊕ (300 Ω/60 mW)
5	In Auxiliary audio ⊕	10	In RS-232 Serial data ⊕ (RXD)	15	In Microphone 2 ⊕ (600 Ω)

\*Ground to activate

### 8 MOLEX CONNECTOR ASSEMBLY

The IC-A210/A210E mates with a Molex connector in the rack mount. Assemble the Molex connector as follows.

#### ◆ Contact terminal assembly

- Strip 4 mm (0.16") from each wire for the contact terminal.
- Open the HTR-6115 Molex hand crimper with the engraved side toward you.
- Insert the stripped conductor until the insulation is even with the side of the crimper facing you.
- Crimp the conductor tab until a crimp is obtained.
- Move the lead to the crimper anvil.
- Place the insulating tab section on the crimper anvil.
- Crimp again until a sufficient crimp is obtained.

#### ◆ Polarizing key

Before installing the Molex connector into the mounting bracket, check the polarizing key position between contacts 8 and 9. Refer to Connector front view in **11 CONNECTOR INFORMATION**.

#### ◆ Contact insertion

Insert the contact terminals into the proper location in the connector housing. Push the terminal until a click is heard.

#### ◆ Contact extraction

Use the Molex contact ejector tool.

- Slip the flat narrow blade of the contact ejector tool under the contact on the mating side of the connector.
- Turn the connector upside down to slide the blade into the slot.
- When the blade is fully in, pull the lead using moderate force.
- Before reinstalling, make sure the tab extends as in the figure below.



### 9 OPERATION CHECK

Check the following points after transceiver installation.

- Polarity of the power supply.
- NO interference caused to other equipment.
- NO noise or interference from other equipment.
- VSWR is less than 2.5:1.
- Communication capability on both the highest and lowest communication frequencies, if possible.

### 10 MOUNTING BRACKET ASSEMBLY

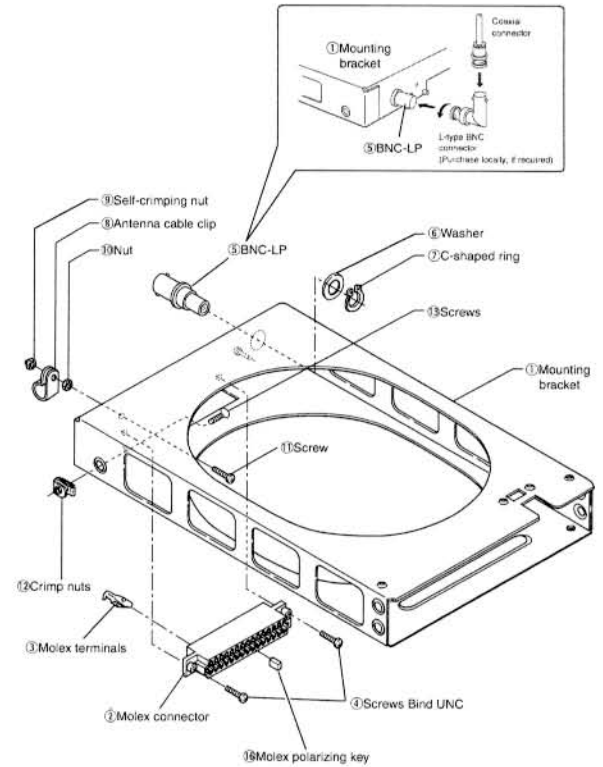

### 11 MARKING MOUNTING HOLES

#### ◆ Notes for making the mounting hole

The IC-A210/A210E can be mounted securely in the supplied mounting bracket.

Remember to allow adequate space for installation of cables and connectors.

When installing 2 or more transceivers in a stack, the mounting trays should be 1.27 mm (0.05") apart.

The mounting bracket has 0.64 mm (0.025") dimples in the top, bottom, and both sides for proper spacing.

Mark and cut the mounting holes.

To support the mounting bracket, the rear mounting bosses should be attached to the airframe.

#### ◆ Mounting bracket dimensions

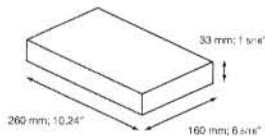

#### ◆ Front panel dimensions



Allow space for the front panel as above.

#### ◆ Template

Cut out dimensions for the mounting bracket as follows.

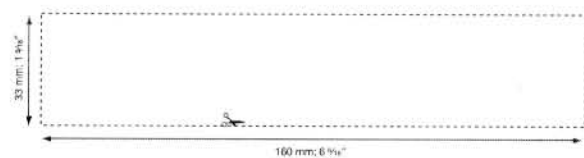

### 12 MOUNTING TO THE BRACKET

#### ◆ Transceiver installation

- Remove the front panel from the main unit, using a 3/32" (2.381mm) allen wrench, then disconnect the flat cable from the front panel. (Fig. 1)
- Insert a 3/32" (2.381mm) allen wrench into the hole of the main unit and unscrew the inside lock screw until the inside metal catch touches the chassis hole. (Fig. 2)
- Use the metal catch located on bottom side of the transceiver when installing into the existing mounting bracket with MB-113.

#### Main unit front view

Use when installing with the original mounting bracket.

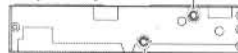

Using this hole when installing with the MB-113.

- Rotate the lock screw clockwise 4 revolutions (Fig. 3), and then rotate counterclockwise a quarter revolution. (Fig. 4)
  - Insert the main unit (transceiver) into the mounting bracket. (Fig. 5)
  - Screw the lock screw to fix the main unit (transceiver) to the bracket. (Fig. 6)
  - Connect the flat cable. (Fig. 7)
- NOTE:** Make sure that the flat cable between the transceiver and front panel is securely connected. The transceiver may not function properly when loose or when a wrong connection is made.
- Attach the front panel and re-screw the allen bolts (Fig. 7).

#### ◆ Transceiver removal

The IC-A210/A210E is easily removed from the mounting bracket, if required.

- Remove the front panel from the main unit, using a 3/32" (2.381mm) allen wrench, then disconnect the flat cable from the front panel.
- Insert a 3/32" (2.381mm) allen wrench into the hole of the main unit and unscrew the inside lock screw.
- Slowly pull the transceiver out from the mounting bracket.
- Connect the flat cable to the front panel.
- Attach the front panel and tighten the allen screws.

